

# CLASSIC CONVERSATION CHAIR INSTRUCTIONS

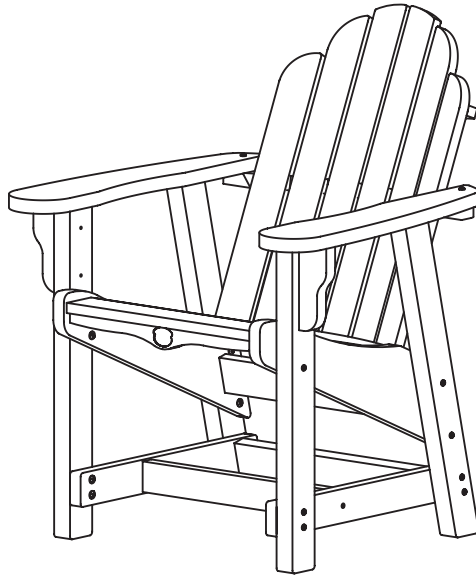

## ASSEMBLY

**STEP 1.** Cut zip ties to remove spreader bar arms from leg assembly. Use (4) 2" screws to attach left and right spreader bar arms to foot rest and spreader bar.

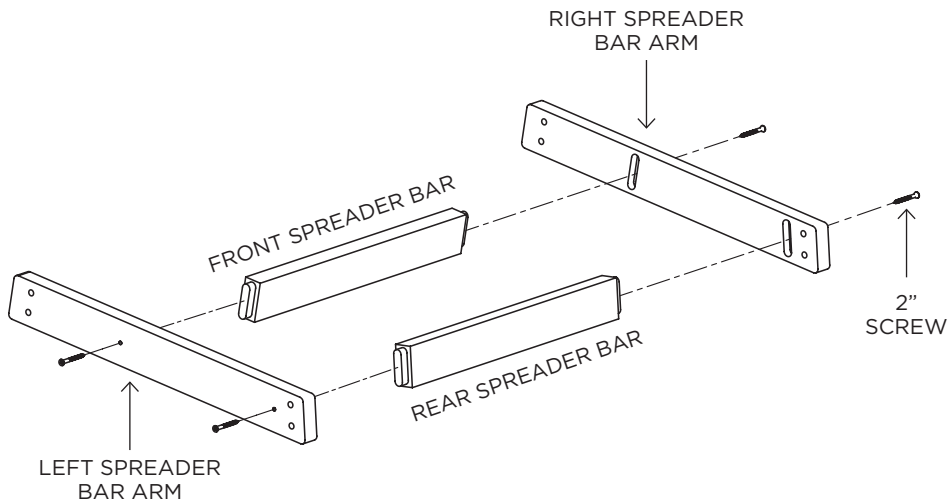

## HARDWARE PACK

Hardware Pack Weight: 11.9 oz.

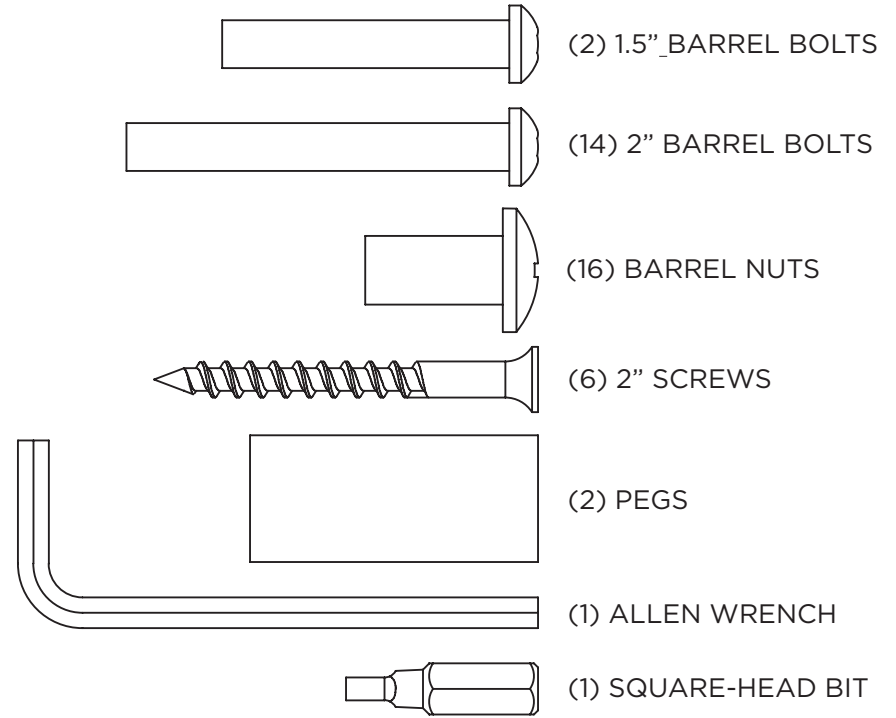

## CHAIR PARTS

- CHAIR BACK
- CHAIR SEAT
- LEFT ARM/LEFT LEG ASSEMBLY
- RIGHT ARM/RIGHT LEG ASSEMBLY
- FRONT SPREADER BAR
- REAR SPREADER BAR
- LEFT SPREADER BAR ARM
- RIGHT SPREADER BAR ARM

## SUGGESTED TOOLS

- RUBBER Mallet
- KNIFE OR SCISSORS
- PHILLIPS HEAD SCREWDRIVER
- DRILL

## ASSEMBLY

**STEP 2.** Use (14) 2" barrel bolts, (14) barrel nuts and (2) pegs to attach right & left arm/leg assembly to chair seat and foot rest. **Keep all barrel bolts loose until Step 4.**

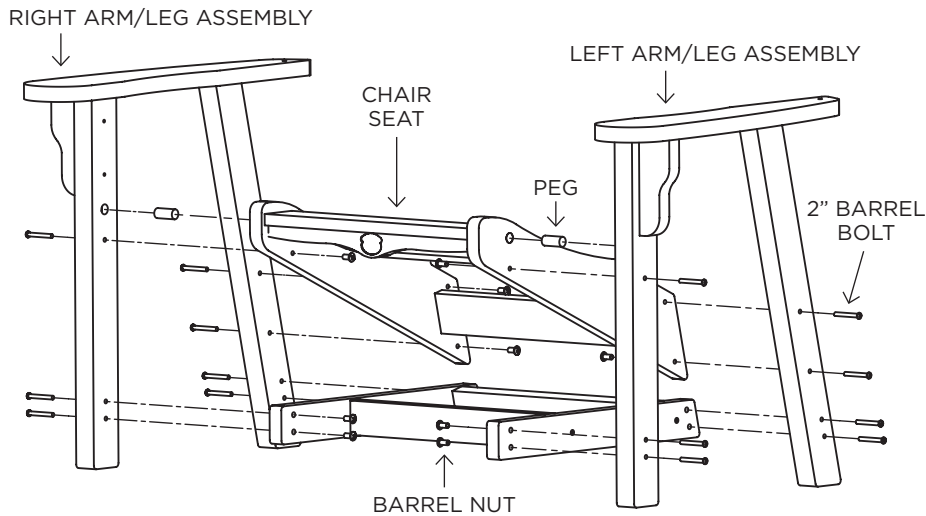

**STEP 3.** Use (2) 1.5" barrel bolts and (2) barrel nuts to attach chair back to right & left arm/leg assembly.

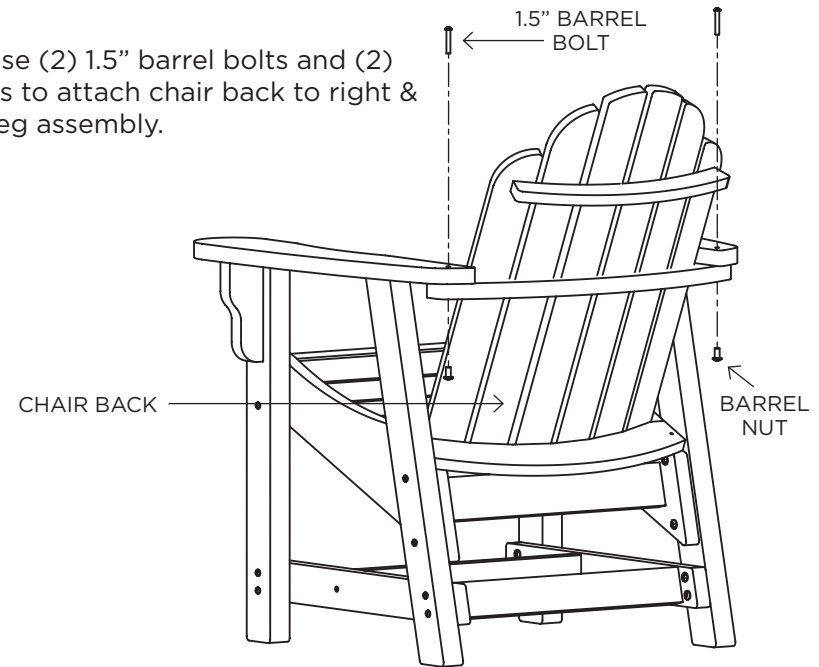

**STEP 4.** Use (2) 2" screws to attach chair back to chair seat. Tighten all bolts once screws are in.

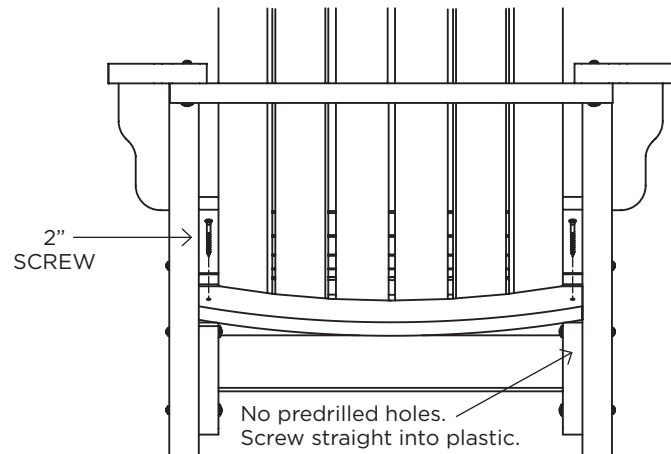

**Congratulations on purchasing this Classic Conversation Chair. QUESTIONS REGARDING THIS PRODUCT? Call our customer service team, 800.643.3522.**

**RESIDENTIAL WARRANTY** - This quality product includes a FULL LIFETIME WARRANTY for RESIDENTIAL CUSTOMERS. In the unlikely event any splintering, rotting, cracking, peeling, chipping, insect infestation or other damage should ever occur, The Hammock Source will replace this furniture, at no charge to you. Note that an original sales receipt must accompany any returned product, along with a Return Authorization Number from Hammock Source customer service; call toll-free at 800.643.3522.

**CONTRACTOR WARRANTY** - CONTRACTORS receive a FULL 7-YEAR WARRANTY. Follow the same steps outlined above.